

MINI EXCAVATORS



Concrete solutions. Always

ES 50 ZT

Operating weight 5.150 - 5.250 kg
Engine Power 33,8 kW - 46,0 HP

ES 57 ZT

Operating weight 5.550 - 5.600 kg
Engine Power 33,8 kW - 46,0 HP

ES 60 TR

Operating weight 5.950 - 6.050 kg
Engine Power 33,8 kW - 46,0 HP



EUROCOMACH®

All three models (ES 50 ZT, ES 57 ZT zero tail and ES 60 TR short round triple arm) are equipped with a side heat engine: this allows the size of the cab to be increased. The blower fan improves engine cooling, making the cabin cooler and quieter for greater operator comfort.



LIKE THE GREATEST, JUST SMALLER.

DIMENSIONS

With short round in model ES 60 TR and the zero tail special features in models ES 50 ZT and ES 57 ZT, you get optimal performance in confined spaces working in complete safety, focusing solely on the excavation operation, even with the cab door open, as it remains within the profile of the tracks.



All models can be equipped with four upright roll-bar protection or cab. The choice allows unmatched versatility: minimum footprint for maximum performance.



ZERO TAIL

The ergonomic driver seat includes servo assisted controls, cushioned seat with arm rests and motion levers with closing pedals.

The foot rest pedals give the operator greater stability during the different work stages, especially when working on slopes.

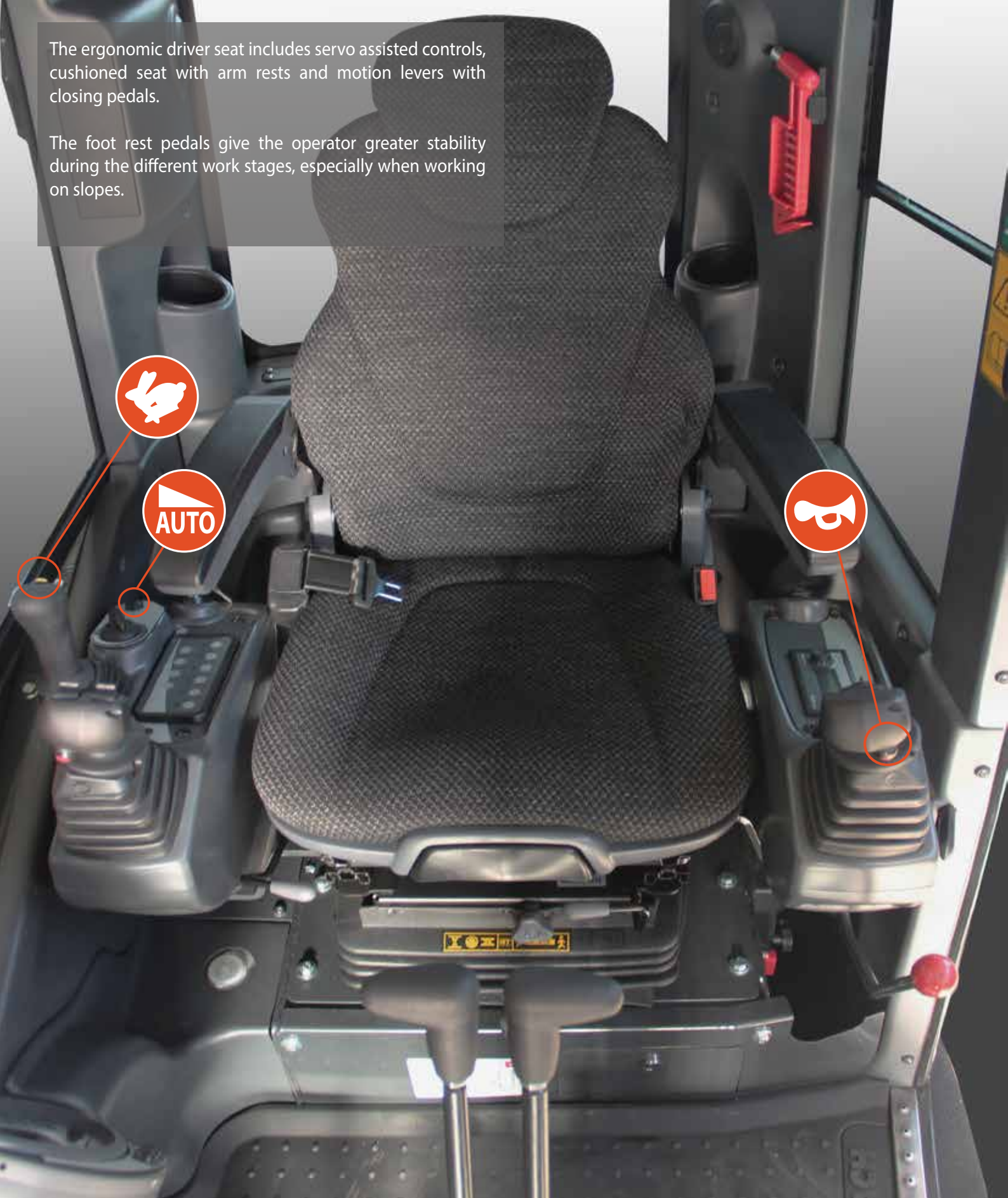

USB RADIO

The radio is equipped with a handy USB port.

COMFORT, SAFETY AND FUNCTIONALITY. FINALLY TOGETHER

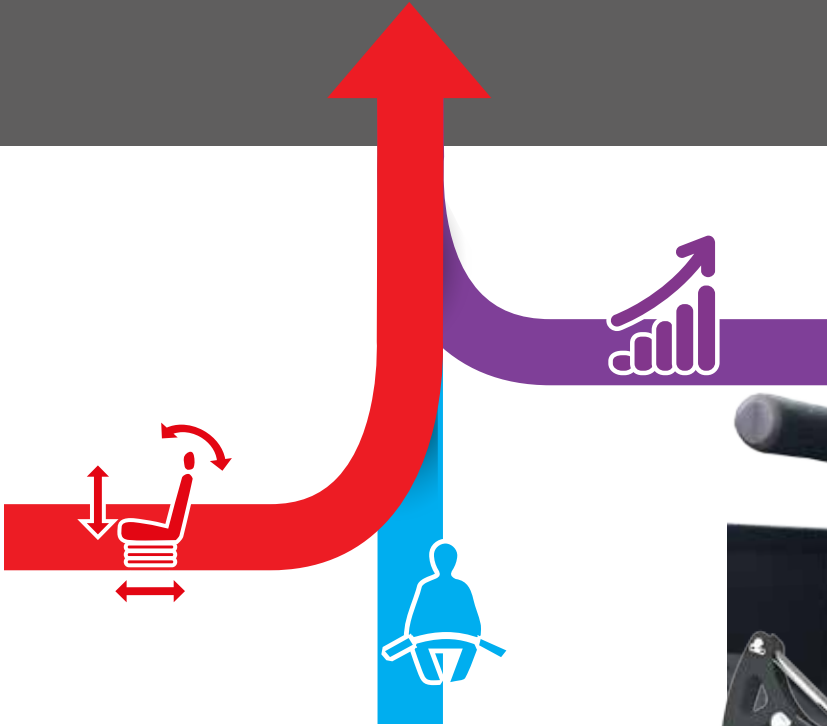

COMMANDS AND CONTROLS

All models have two motion modes: first gear with reduced speed and high thrust force and second speed with greater transfer speed. Everything is controlled by a practical button above the backfill blade lever. Motion can be controlled using the advancement lever and integrated folding pedals that, once closed, increase the space available to the operator and prevent accidental use.

The foot board flush with the door makes for stepless exit from the cab and facilitates floor cleaning operations. It was designed to be able to be removed easily in order to perform extraordinary maintenance.



STRAIGHT TRAVEL

In case of simultaneous control of the services and motion, the hydraulic system with variable displacement pumps simultaneously ensures the fluidity of movements and straight driving of the machine.



AUTO TWO SPEED

When the excavator needs more thrust force, the automatic speed transmission intervenes, reducing the motion ratio.

The cabin, with its generous interior dimensions, offers some of the best interior space in its class. The large width of the access door makes it easy to climb in and out. The front windshield with assisted lift promotes maximum visibility due to its considerable width.

The adjustable suspension seat combined with the floating cabin, adequately dampens vibrations and bumps, maximizing operator comfort. The cab is equipped with a radio, glove compartment, USB port, courtesy light, sliding sunblind, battery charger and other practical accessories.

The multifunction display allows the operator to view the machine status and choose the various use configurations using simple and intuitive commands. The lighted and analogue indicators along with audible alarms ensure immediate control of the primary functions.



The tilting controls, triple arm (ES 60 TR) and auxiliary hydraulic system are controlled through convenient and precise proportional electro-hydraulic rollers located on the joysticks.

VISIBILITY

The special design of the body and protective structures give the operator a wide field of vision, allowing easy control of the front tracked part.

The large windshield along with the upper rear window lets the operator keep an eye on the entire work area while remaining comfortably seated.



WORK LIGHTS

Powerful lights built into the arm and in the lower compartments optimize visibility even with low lighting.

LOAD SENSING HYDRAULIC SYSTEM

The efficient Load Sensing system saves fuel (up to 15%) with the suitable power distribution.

LS pump: only delivers the flow required by the system.

FLOW SHARING distributor: full simultaneous movements (all), even when the flow required exceeds the maximum pump capacity.

Optimal flow in each element thanks to the pressure compensators in each section.

High flexibility: the flow and pressure regulators provide high-speed during empty movements and high pressure while working.

Availability of various auxiliary systems with capacities from 35 up to 85 lt/min.



FLEXIBILITY, COMPACTNESS, ERGONOMICS.

The practical additional external ballast (optional) can, when needed, further increase the excellent operating stability without compromising the overall size of the machine.

EFFICIENCY AND CONSUMPTION

The heart of the excavators is the efficient and silent KUBOTA V2607-DI engine designed and built to optimize performance and reduce fuel consumption.

The long intervals between programmed maintenance contribute to economic efficiency, reducing costs and machine downtime.

The Auto-Idle automatic controls reduce the engine rpm when the hydraulic system is not in use, controlling fuel consumption.

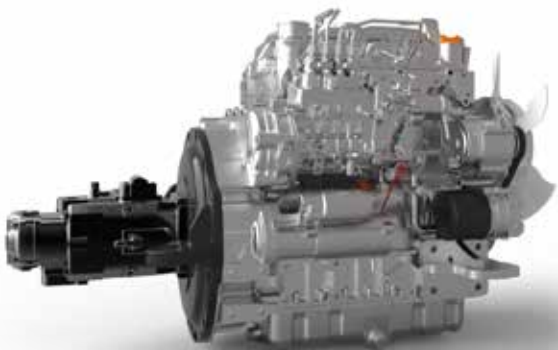

SAFETY

Sensors monitoring the manipulator position prevent accidental control of the machine. Safety belts, the cabin structure and rollbar with ROPS FOPS level I and TOPS certificate provide all of the safety needed in the cab in the event of an accident.



OPTIONAL COUNTERWEIGHT



MAINTENANCE HAS NEVER BEEN SO EASY.



The quick and practical cab tipping minimizes machine down time during extraordinary maintenance on the hydraulic system.



ACCESSIBILITY

Services related to the heat engine are easily reached through a wide opening and the side compartment. All the filters (fuel, oil and air) in addition to checking and topping up the engine oil, are easily identified on the side.

It is simple and easy to clean all of the radiators thanks to the front compartment opening.



The rear compartment allows quick access to the electronic pump to refill the fuel and to the hydraulic distributor.



A practical tool compartment is available to the operator on the machine entry side.

All access points for daily checks and for routine maintenance are concentrated in defined areas, optimizing machine downtime.



ACCESSIBILITY

Common or dedicated access areas make every maintenance operation quick and easy.

SPACE FOR SERVICES



THE IMPORTANCE OF BEING RELIABLE.

RELIABILITY

Designed and tested for high performance with continuous reliability.

The definition of the materials, the selection of components and design of the structures were created to exceed the most stressful and harsh work tests.

Standing out among these are the rotation column in fusion, the protections on the lifting cylinder and the steel blade and bonnets that increase efficiency and life of the product.



PERFORMANCE

ECS: ONE CONCEPT, NUMEROUS POSSIBILITIES.

UTILITIES AND SERVICES

We listen to all your needs so we can propose the best possible machine solution.

We consider our products to be not only simple machines but the best opportunity for our clients.

Among the services provided, the following are available:

- Customized paint
- Various types of tracks
- Auxiliary line hookups customized by type and quantity
- Additional equipment

The many configurations available allow you to make the best choice in relation to the work to be performed.



SATELLITE MONITORING SYSTEM.



EUROCOMACH GEOSERVICE

- Precise location of the machine on the Internet
- Antitheft device with alarm and notification via SMS/email
- High water temperature or low engine oil pressure alarm with notification via SMS/email
- Use time monitoring with alarm for service due

OPTIONALS.

The wide range of equipment especially designed for Eurocomach mini excavators ensures the most appropriate use of the machine, maximizing performance.

A complete offer of optional fittings ensures the best performance.



Triple pedal arm



Proportional electronic roller for auxiliary hydraulic system on left Joystick



Certified and tested lifting hook and blocking valves with CE certification for material handling equipment



Additional front and rear protective grills with FOPS level II certification



Hydraulic dozer tilt angle backfill blade with extension and additional cutting edge guard



Single/double effect hydraulic system with electrical containment (70 lt/min)



Hydraulic thumb



Customized paint



	ES 60 TR		
	ES 57 ZT		
	ES 50 ZT		
ENGINE			
Diesel engine, 4 cylinders, displacement 2615 cc, watercooled	●	●	●
Electronic throttle with automatic idle speed system (Auto Idle)	●	●	●
Electric preheater	●	●	●
Dry air filter with discharge valve and filter clogged indicator	●	●	●
Double cartridge air filter	●	●	●
Cartridge engine oil filter	●	●	●
Cartridge fuel filter	●	●	●
Fuel filter with transparent water separation container	●	●	●
Fuel tank discharge	●	●	●
Auxiliary liquid refrigerant expansion tank	●	●	●
CAB			
Cab ROPS - TOPS - FOPS (Level I)	●	●	●
Adjustable mechanical suspension seat	●	●	●
Adjustable pneumatic suspension seat	○	○	○
Adjustable, heated pneumatic suspension seat	○	○	○
Safety Belt	●	●	●
Elbow support arm rests	●	●	●
Foot supports	●	●	●
Closable motion petals	●	●	●
Comfort rubber foot rest	●	●	●
Drivers seat platform assembled on 4 vibration damping elastic supports	●	●	●
Air-conditioning with automatic adjustment	○	●	●
Sliding right side window	●	●	●
Sliding left side window	●	●	●
Windshield with assisted opening system (gas springs)	●	●	●
Rolling sun blind	●	●	●
Courtesy light	●	●	●
Indicator light for hydraulic filter and engine air intake filter clog	●	●	●
Water temperature and fuel level indicators	●	●	●
Counter	●	●	●
High water temperature alarm	●	●	●
Warning buzzer	●	●	●
Radio AM/FM USB	○	○	○
Single pole 12 volt power supply outlet	●	●	●
Front windshield wipers with sprayer and speed control	●	●	●
Glove compartment	●	●	●
Bottle holder	●	●	●

	ES 60 TR		
	ES 57 ZT		
	ES 50 ZT		
CANOPY			
4 upright rollbar ROPS - TOPS - FOPS (Level I)	○	○	○
Adjustable mechanical suspension seat	●	●	●
Adjustable pneumatic suspension seat	○	○	○
Safety Belt	●	●	●
Elbow support arm rests	●	●	●
Foot supports	●	●	●
Closable motion petals	●	●	●
Comfort rubber foot rest	●	●	●
Drivers seat platform assembled on 4 vibration damping elastic supports	●	●	●
Indicator light for hydraulic filter and engine air intake filter clog	●	●	●
Water temperature and fuel level indicators	●	●	●
Counter	●	●	●
High water temperature alarm	●	●	●
Warning buzzer	●	●	●
Single pole 12 volt power supply outlet	●	●	●
Glove compartment	●	●	●
Bottle holder	●	●	●
SAFETY			
Machine blocking device during exit/ access to the driver's seat	●	●	●
Engine ignition device only with the left console lowered	●	●	●
Anti-slip climbing plate	●	●	●
Climbing and descending handles	●	●	●
Emergency bar	●	●	●
Rearview mirror kit	●	●	●
Rearview camera kit with dedicated colour monitor	○	○	○
Upper FOPS (level II) protective grille	○	○	○
Front cab protective grille	○	○	○
Anti-drift safety valve on the first arm, second arm and backfill blade	○	○	○
Pressure accumulator that allows the arm to be lowered in the event of an engine failure	●	●	●
ELECTRIC SYSTEM			
Work lights on the lifting arm	●	●	●
Supplementary work lights on the lifting arm	○	○	○
Supplementary front canopy/cap lights	○	○	○
Supplementary rear canopy/cap lights	○	○	○
Rotating light	○	○	○
Battery disconnect switch	●	●	●
Watertight connectors (IP67)	●	●	●

	ES 60 TR		
	ES 57 ZT		
	ES 50 ZT		
HYDRAULIC SYSTEM			
Load-sensing hydraulic system with variable capacity pump	●	●	●
ISO hydraulic servo-control	●	●	●
Hydraulic oil intake filter	●	●	●
Rotation parking brake	●	●	●
Motion parking brake	●	●	●
Two speed motion system	●	●	●
Automatic movement speed change (Shift-down)	●	●	●
Single/double effect hydraulic system (e.g., hammer or drill) with electrical containment	●	●	●
Hydraulic setup for calliper rotor (with switches on bucket cylinder)	○	○	○
AUX 2: System setup for calliper rotor with proportional electro-hydraulic control on the Right joystick	○	○	○
AUX 3: Double effect low capacity hydraulic set up with potentiometer control on the left joystick (excludes tilt operation)	/	●	●
Hydraulic drainage line directly to the tank	/	●	●
UNDERCARRIAGE			
Backfill blade	●	●	●
Adjustable backfill blade (only for ES 50 ZT available equipped with the undercarriage of ES 57 ZT)	○	○	○
Adjustable and tilting backfill blade	○	○	○
Dozer blade cylinder protective casing	●	●	●
Motion engines casing	●	●	●
Rotating joint protective casing	●	●	●
Rubber tracks	●	●	●
"Roadliner track" rubberized pad	○	○	○
Iron tracks	○	○	○
Rubber road pad for iron tracks	○	○	○
4 anchoring points for transport	●	●	●
UTILITY			
Antitheft system	○	○	○
Geo-service system for locating and remote diagnostics	○	○	○
Second excavating arm 1,500 mm	●	/	/
Second excavating arm 1,650 mm	○	●	●
Second excavating arm 1,900 mm	/	○	○
Additional external counterweight	○	○	○
Platform roll bar / tippable cab	●	●	●
Colour customizations (RAL specific)	○	○	○
4 anchoring points for lifting	●	●	●
On-board visual fuel level indicator	●	●	●
Fuel refill pump with automatic shutdown	○	●	●
Tool compartment	●	●	●
Lifting cylinder protective casing	●	●	●

STANDARD EQUIPMENT ●
 OPTIONAL EQUIPMENT ○
 NOT AVAILABLE /

TECHNICALS SPECIFICATIONS

Operating weight with canopy (with rubber tracks)	kg	5.150
Operating weight with cabin (with rubber tracks)	kg	5.250
Travelling speed (AUTO TWO SPEED)	km/h	1 ^a : 0 ÷ 2,6 / 2 ^a : 0 ÷ 5,2
Slew speed	rpm	11

ENGINE

Type	KUBOTA V2607-DI	
Max Power (2.200 rpm)	kW - HP	33,8 - 46,0
Displacement	cc	2.615
Number of cylinders	n°	4
Cooling	water	
Consumption	lt/h	6,1
Alternator	V (A)	12 (60)
Battery	V (Ah)	12 (100)

HYDRAULIC SYSTEM

Circuit Type	load sensing closed center system with flow sharing control valve	
Pump type	1 ls variable pump + 1 gear pump	
Pump displacement	cc	65 + 8
Pump capacity	lt/min	140 + 17
Max. circuit calibration pressure	bar	260
Auxiliary Flow (max pressure): AUX 1 main high flow simple or double effect	lt/min (bar)	70 / 70 (200)

PERFORMANCES

Max digging depth standard arm (optional arm)	mm	3.600 (3.750)
Max dumping height with cab standard arm (optional arm)	mm	3.950 (4.050)
Bucket breaking force (standard arm) ISO 6015	daN	4.500
Arm breaking force (standard arm) ISO 6015	daN	2.800
Traction force	daN	5.200
Ground bearing pressure with rubber tracks and canopy (with cabin)	kg/cm ²	0,33 (0,34)
Max slope	60% - 30°	

DIMENSIONS

Maximum width	mm	1.980
Total height	mm	2.560
Rear rotation radius	mm	1.000
Digging arm length std (optional)	mm	1.500 (1.650)
Tracks width	mm	400
Rollers number (for each side)	n°	5/1

FILLINGS

Fuel tank	lt	70
Hydraulic oil tank	lt	65
Hydraulic circuit capacity	lt	85
Cooling system capacity	lt	12
Engine oil	lt	9

CONTROLS

Boom, dipper stick, bucket and turret swing	2 pilot joysticks	
Track movements (included counter rotation)	2 pilot levers	
Dozer blade	pilot lever	
Auxiliary circuit (simple or double effect)	electroproportional switch on right joystick	
Boom swing	electroproportional switch on left joystick	

TECHNICALS SPECIFICATIONS

Operating weight with canopy (with rubber tracks)	kg	5.500
Operating weight with cabin (rubber tracks)	kg	5.600
Travelling speed (AUTO TWO SPEED)	km/h	1 ^a : 0 ÷ 2,6 / 2 ^a : 0 ÷ 5,2
Slew speed	rpm	11

ENGINE

Type	KUBOTA V2607-DI	
Max Power (2.200 rpm)	kW - HP	33,8 - 46,0
Displacement	cc	2.615
Number of cylinders	n°	4
Cooling	water	
Consumption	lt/h	6,1
Alternator	V (A)	12 (60)
Battery	V (Ah)	12 (100)

HYDRAULIC SYSTEM

Circuit Type	load sensing closed center system with flow sharing control valve	
Pump type	1 ls variable pump + 1 gear pump	
Pump displacement	cc	65 + 8
Pump capacity	lt/min	140 + 17
Max. circuit calibration pressure	bar	260
Auxiliary Flow (max pressure):	lt/min (bar)	
AUX 1 main high flow simple or double effect		70 - 70 (200)
AUX 2 double effect		35 - 50 (260)

PERFORMANCES

Max digging depth standard arm (optional arm)	mm	3.850 (4.100)
Max dumping height with cab standard arm (optional arm)	mm	4.090 (4.240)
Bucket breaking force (standard arm) ISO 6015	daN	4.500
Arm breaking force (standard arm) ISO 6015	daN	2.800
Traction force	daN	5.200
Ground bearing pressure with rubber tracks and canopy (with cabin)	kg/cm ²	0,33 (0,34)
Max slope	60% - 30°	

DIMENSIONS

Maximum width	mm	1.980
Total height	mm	2.560
Rear rotation radius	mm	1.000
Digging arm length std (optional)	mm	1.650 (1.900)
Tracks width	mm	400
Rollers number (for each side)	n°	5/1

FILLINGS

Fuel tank	lt	70
Hydraulic oil tank	lt	65
Hydraulic circuit capacity	lt	85
Cooling system capacity	lt	12
Engine oil	lt	9

CONTROLS

Boom, dipper stick, bucket and turret swing	2 pilot joysticks
Track movements (included counter rotation)	2 pilot levers
Dozer blade	pilot lever
Auxiliary circuit (simple or double effect)	electroproportional switch on right joystick
Boom swing	electroproportional switch on left joystick

TECHNICALS SPECIFICATIONS

Operating weight with canopy (with rubber tracks)	kg	5.950
Operating weight with cabin (rubber tracks)	kg	6.050
Travelling speed (AUTO TWO SPEED)	km/h	1 ^a : 0 ÷ 2,6 / 2 ^a : 0 ÷ 5,2
Slew speed	rpm	11

ENGINE

Type	KUBOTA V2607-DI	
Max Power (2.200 rpm)	kW - HP	33,8 - 46,0
Displacement	cc	2.615
Number of cylinders	n°	4
Cooling	water	
Consumption	lt/h	6,1
Alternator	V (A)	12 (60)
Battery	V (Ah)	12 (100)

HYDRAULIC SYSTEM

Circuit Type	load sensing closed center system with flow sharing control valve	
Pump type	1 ls variable pump + 1 gear pump	
Pump displacement	cc	65 + 8
Pump capacity	lt/min	140 + 17
Max. circuit calibration pressure	bar	260
Auxiliary Flow (max pressure):	lt/min (bar)	
AUX 1 main high flow simple or double effect		70 - 70 (200)
AUX 2 double effect		35 - 50 (260)

PERFORMANCES

Max digging depth standard arm (optional arm)	mm	3.950 (4.200)
Max dumping height with cab standard arm (optional arm)	mm	5.400 (5.640)
Bucket breaking force (standard arm) ISO 6015	daN	4.500
Arm breaking force (standard arm) ISO 6015	daN	2.800
Traction force	daN	5.200
Ground bearing pressure with rubber tracks and canopy (with cabin)	kg/cm ²	0,36 (0,37)
Max slope	60% - 30°	

DIMENSIONS

Maximum width	mm	1.980
Total height	mm	2.560
Rear rotation radius	mm	1.075
Digging arm length std (optional)	mm	1.650 (1.900)
Tracks width	mm	400
Rollers number (for each side)	n°	5/1

FILLINGS

Fuel tank	lt	70
Hydraulic oil tank	lt	65
Hydraulic circuit capacity	lt	85
Cooling system capacity	lt	12
Engine oil	lt	9

CONTROLS

Boom, dipper stick, bucket and turret swing	2 pilot joysticks	
Track movements (included counter rotation)	2 pilot levers	
Dozer blade	pilot lever	
Auxiliary circuit (simple or double effect)	electroproportional switch on right joystick	
Boom swing	electroproportional switch on left joystick	

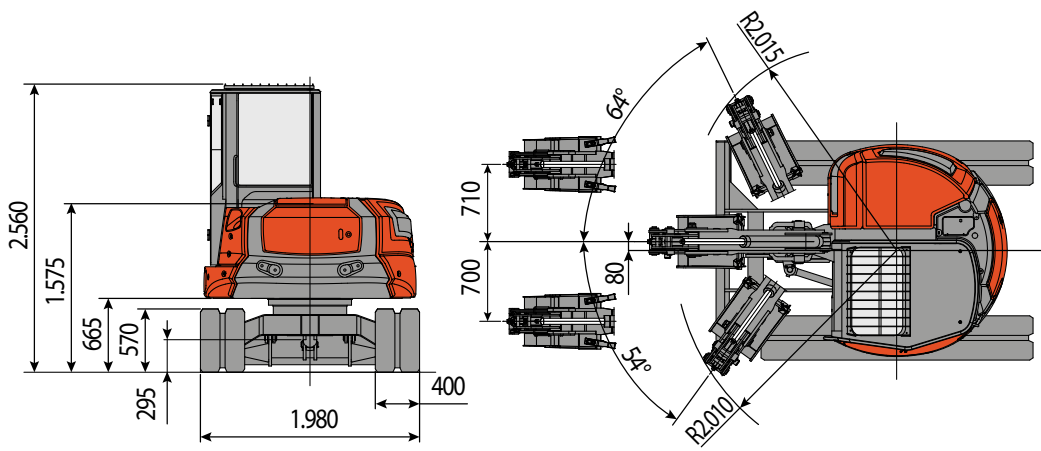
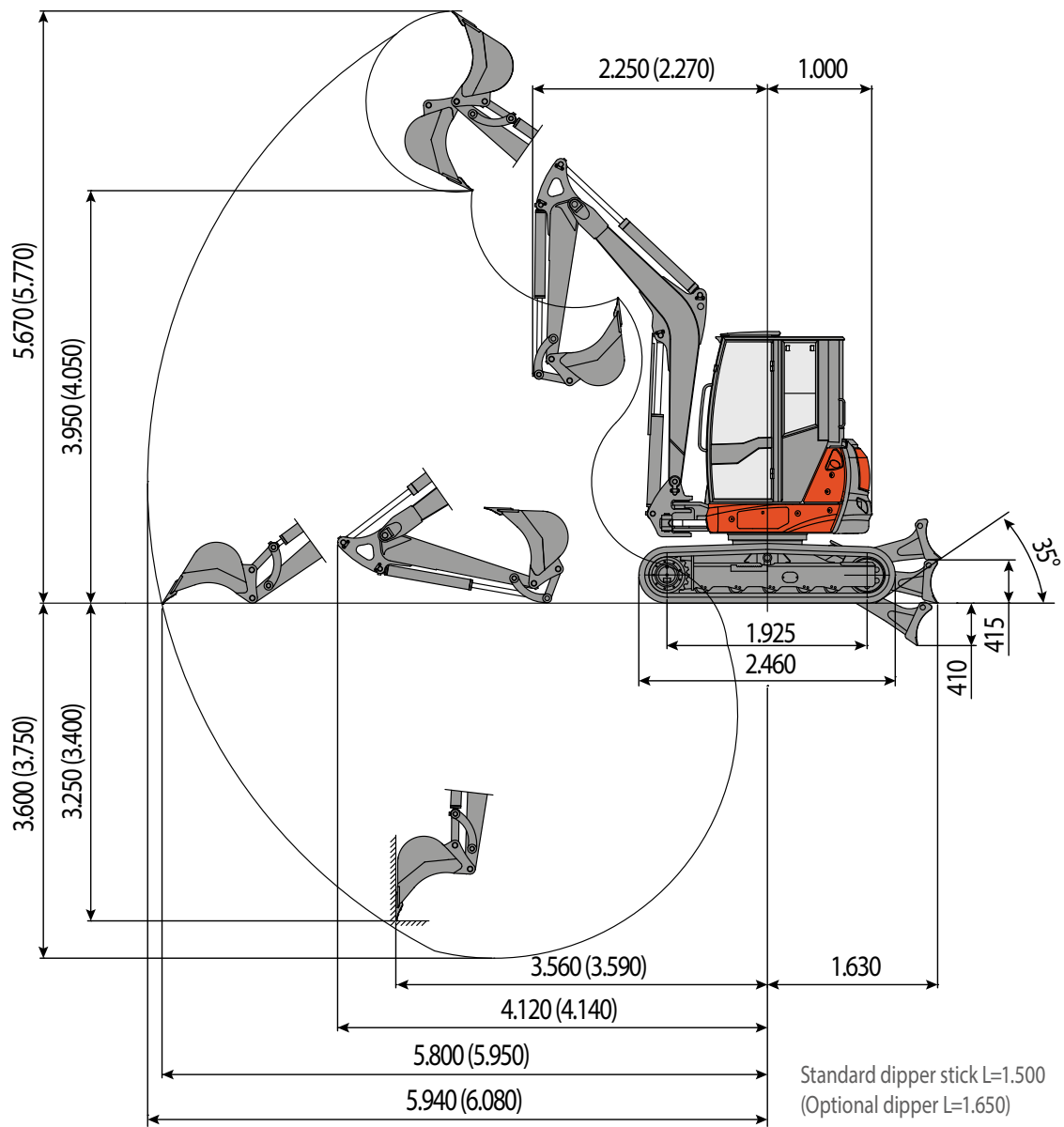

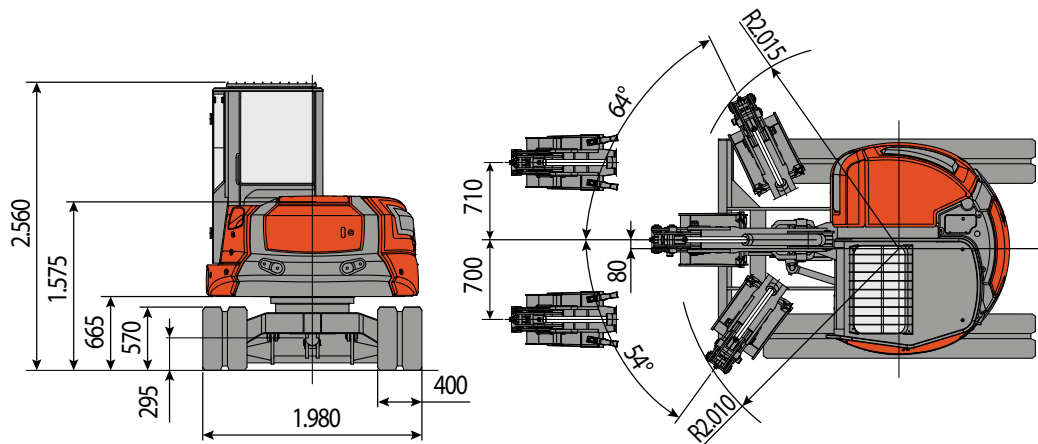
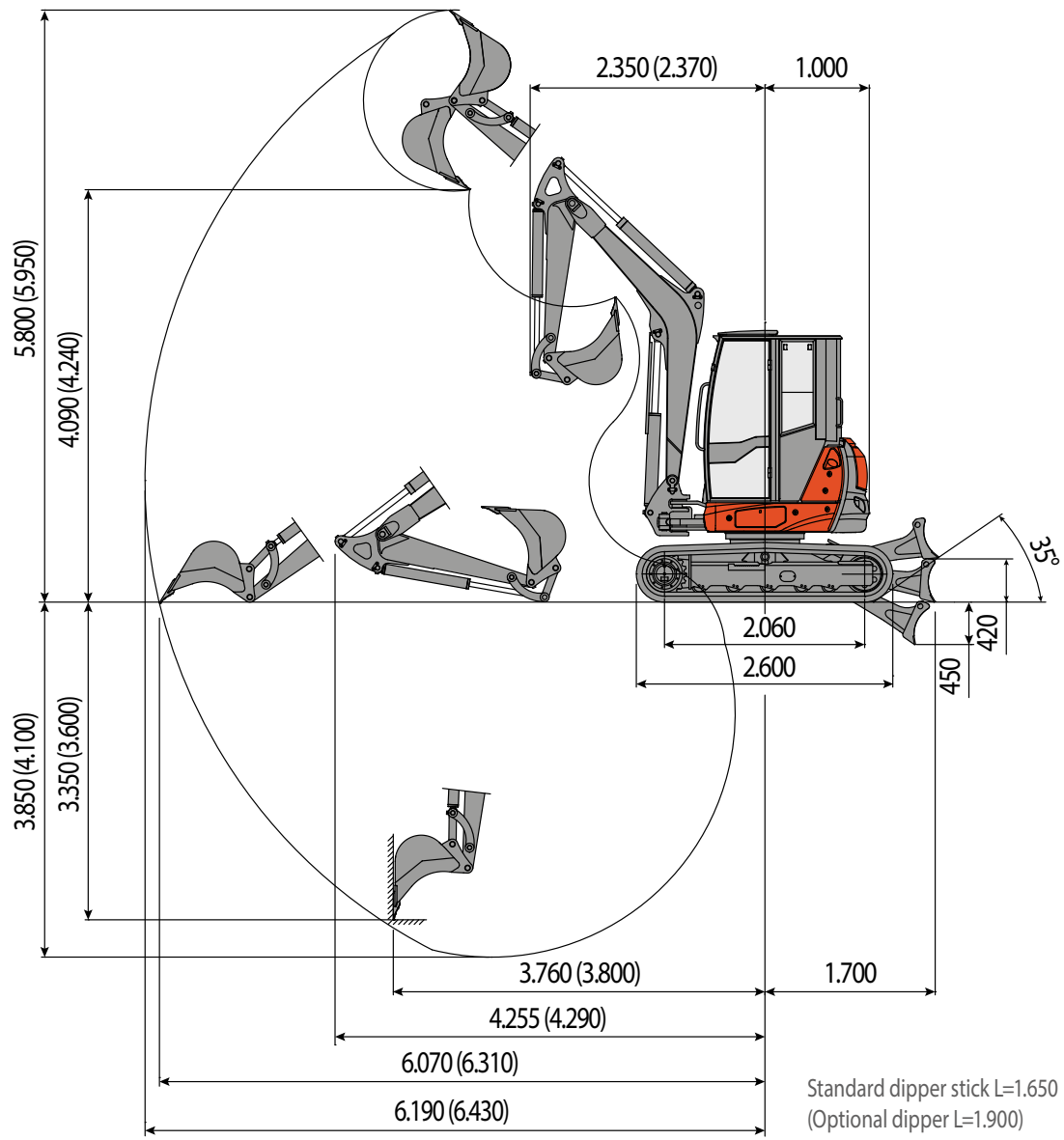

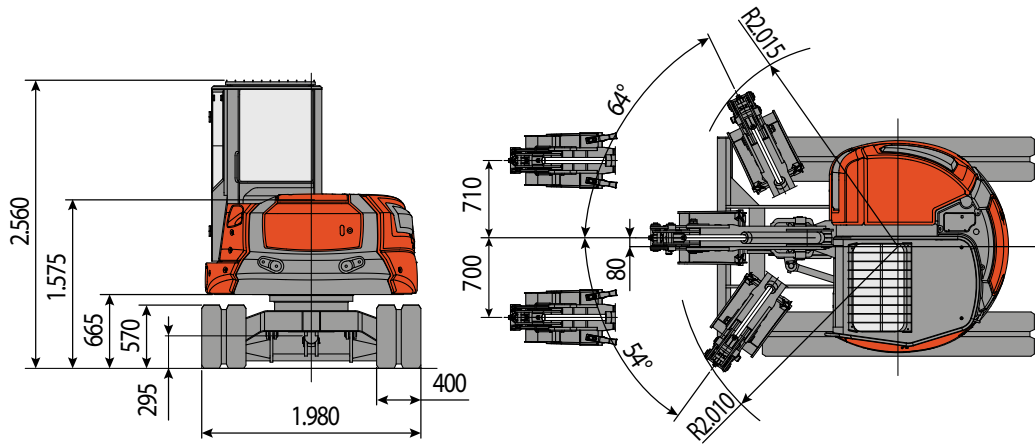
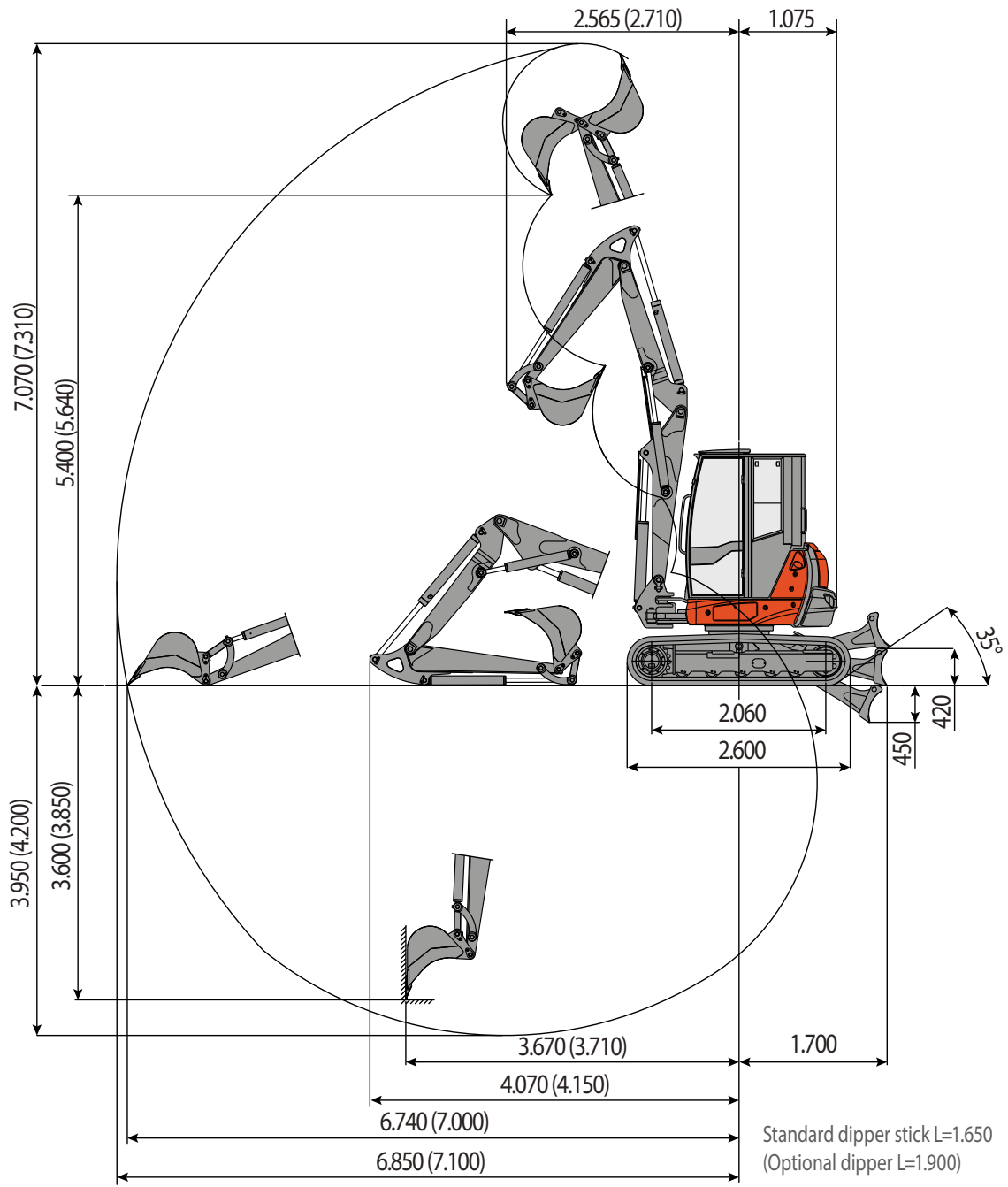

LIFTING CAPACITY

The lifting capacity is based on ISO 10567 and does not exceed 75% of the static tipping load or 87% of the hydraulic lifting capacity of the machine.

The straddle refers to the centre of rotation.

* Indicates the hydraulic load limit.

0 m refers to ground level.

The machine is understood to be equipped with a cab, rubber tracks, without a bucket and without a quick coupling.

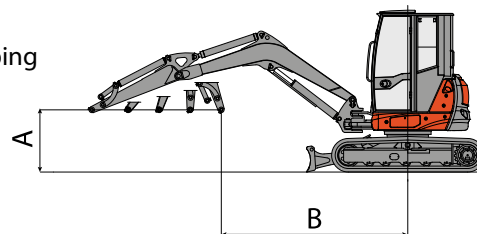

Front



Side

Unit: ton

Blade raised, Standard Arm (1500 mm)

() the values in parenthesis are with additional ballast: 0.25 ton

A (m)	B (m)										
	1.0		2.0		3.0		4.0		MAX		
4.0					1,23 (1,41)	1,05 (1,23)			0,6 (0,72)	0,57 (0,69)	3,99 m
3.0					1,26 (1,44)	1,08 (1,26)	0,81 (0,93)	0,84 (0,96)	0,63 (0,72)	0,54 (0,64)	4,67 m
2.0					1,27 (1,45)	1,11 (1,29)	0,82 (0,94)	0,82 (0,94)	0,64 (0,73)	0,52 (0,61)	5,00 m
1.0					1,3 (1,48)	1,14 (1,32)	0,88 (1)	0,78 (0,9)	0,67 (0,76)	0,54 (0,62)	5,08 m
0					1,32 (4,09)	1,17 (1,35)	0,9 (1,02)	0,72 (0,84)	0,65 (0,74)	0,57 (0,66)	4,92 m
-1.0	*1,91 (*1,91)	*1,9 (*1,9)	*1,67 (*1,67)	1,27 (1,62)	1,27 (1,45)	1,1 (1,28)	0,93 (1,05)	0,7 (0,82)	0,66 (0,76)	0,6 (0,7)	4,49 m
-2.0	*1,94 (*1,94)	*1,93 (*1,93)	*1,72 (*1,72)	1,3 (1,65)	1,26 (1,44)	*1,25 (*1,25)			0,66 (0,8)	0,63 (0,76)	3,65 m

Blade lowered, Standard Arm (1500 mm)

() the values in parenthesis are with additional ballast: 0.25 ton

A (m)	B (m)										
	1.0		2.0		3.0		4.0		MAX		
4.0					*1,66 (*1,66)	*1,21 (*1,21)			*1,09 (*1,09)	0,57 (0,69)	3,99 m
3.0					*1,79 (*1,79)	1,08 (1,21)	*1,23 (*1,23)	0,84 (0,96)	*1,13 (*1,13)	0,54 (0,64)	4,67 m
2.0					*1,84 (*1,84)	1,11 (1,26)	*1,37 (*1,37)	0,82 (0,94)	*1,2 (*1,2)	0,52 (0,61)	5,00 m
1.0					*2,33 (*2,33)	1,14 (1,29)	*1,61 (*1,61)	0,78 (0,9)	*1,29 (*1,29)	0,54 (0,62)	5,08 m
0					*2,37 (*2,37)	1,17 (1,32)	*1,69 (*1,69)	0,72 (0,84)	*1,28 (*1,28)	0,57 (0,66)	4,92 m
-1.0	*1,91 (*1,91)	*1,9 (*1,9)	*1,67 (*1,67)	1,27 (1,62)	*2,34 (*2,34)	1,1 (1,35)	*1,62 (*1,62)	0,7 (0,82)	*1,16 (*1,16)	0,6 (0,7)	4,49 m
-2.0	*1,94 (*1,94)	*1,93 (*1,93)	*1,72 (*1,72)	1,3 (1,65)	*1,93 (*1,93)	*1,25 (*1,28)			*1,13 (*1,13)	0,63 (0,76)	3,65 m



Front



Side

Unit: ton

Blade raised, Optional Arm (1650 mm)

() the values in parenthesis are with additional ballast: 0.25 ton

A (m)	B (m)										
	1.0		2.0		3.0		4.0		MAX		
4.0					1,22 (1,4)	1,03 (1,21)			0,54 (0,66)	0,51 (0,63)	4,19 m
3.0					1,24 (1,42)	1,07 (1,25)	0,79 (0,92)	0,82 (0,95)	0,56 (0,66)	0,48 (0,58)	4,83 m
2.0					1,26 (1,44)	1,1 (1,28)	0,81 (0,93)	0,81 (0,93)	0,58 (0,67)	0,46 (0,55)	5,16 m
1.0					1,29 (1,47)	1,13 (1,31)	0,87 (0,99)	0,76 (0,89)	0,61 (0,7)	0,47 (0,56)	5,23 m
0					1,3 (4,07)	1,15 (1,33)	0,88 (1,01)	0,7 (0,83)	0,59 (0,68)	0,5 (0,6)	5,08 m
-1.0	*1,9 (*1,9)	*1,89 (*1,89)	*1,65 (*1,65)	1,26 (1,61)	1,26 (1,44)	1,09 (1,27)	0,92 (1,04)	0,69 (0,81)	0,59 (0,7)	0,53 (0,64)	4,66 m
-2.0	*1,92 (*1,92)	*1,92 (*1,92)	*1,71 (*1,71)	1,29 (1,64)	1,24 (1,42)	1,24 (1,24)			0,6 (0,74)	0,56 (0,7)	3,87 m

Blade lowered, Optional Arm (1650 mm)

() the values in parenthesis are with additional ballast: 0.25 ton

A (m)	B (m)										
	1.0		2.0		3.0		4.0		MAX		
4.0					*1,65 (*1,65)	*1,2 (*1,2)			*1,03 (*1,03)	0,51 (0,63)	4,19 m
3.0					*1,78 (*1,78)	1,07 (*1,2)	*1,22 (*1,22)	0,82 (0,95)	*1,07 (*1,07)	0,48 (0,58)	4,83 m
2.0					*1,83 (*1,83)	1,1 (*1,25)	*1,36 (*1,36)	0,81 (0,93)	*1,13 (*1,13)	0,46 (0,55)	5,16 m
1.0					*2,32 (*2,32)	1,13 (1,28)	*1,6 (*1,6)	0,76 (0,89)	*1,23 (*1,23)	0,47 (0,56)	5,23 m
0					*2,36 (*2,36)	1,15 (1,31)	*1,68 (*1,68)	0,7 (0,83)	*1,22 (*1,22)	0,5 (0,6)	5,08 m
-1.0	*1,9 (*1,9)	*1,89 (*1,89)	*1,65 (*1,65)	1,26 (1,61)	*2,33 (*2,33)	1,09 (1,33)	*1,61 (*1,61)	0,69 (0,81)	*1,1 (*1,1)	0,53 (0,64)	4,66 m
-2.0	*1,92 (*1,92)	*1,92 (*1,92)	*1,71 (*1,71)	1,29 (1,64)	*1,92 (*1,92)	*1,24 (*1,27)			*1,07 (*1,07)	0,56 (0,7)	3,87 m

LIFTING CAPACITY

The lifting capacity is based on ISO 10567 and does not exceed 75% of the static tipping load or 87% of the hydraulic lifting capacity of the machine.

The straddle refers to the centre of rotation.

* Indicates the hydraulic load limit.

0 m refers to ground level.

The machine is understood to be equipped with a cab, rubber tracks, without a bucket and without a quick coupling.

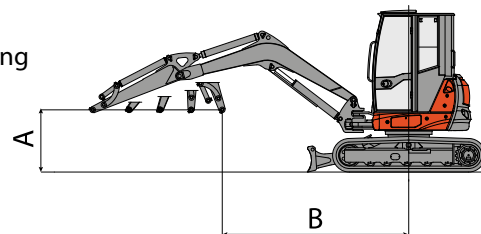

Front

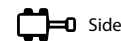

Side

Unit: ton

Blade raised, Standard Arm (1650 mm)

() the values in parenthesis are with additional ballast: 0.25 ton

A (m)	B (m)										MAX
	1.0		2.0		3.0		4.0		MAX		
4.0					1,83 (2,01)	1,42 (1,6)	1,16 (1,28)	0,94 (1,06)	0,59 (0,7)	0,73 (0,84)	4,19 m
3.0					1,83 (2,01)	1,41 (1,59)	1,15 (1,27)	0,93 (1,05)	0,6 (0,7)	0,7 (0,79)	4,83 m
2.0					1,8 (1,98)	1,41 (1,59)	1,14 (1,26)	0,93 (1,05)	0,61 (0,7)	0,67 (0,76)	5,16 m
1.0					1,79 (1,97)	1,38 (1,56)	1,12 (1,24)	0,9 (1,02)	0,82 (0,9)	0,65 (0,73)	5,23 m
0					1,81 (1,99)	1,35 (1,53)	1,14 (1,26)	0,87 (0,99)	0,61 (0,7)	0,66 (0,74)	5,08 m
-1.0	1,98 (8,98)	2,4 (9,39)	1,83 (2,18)	1,44 (1,79)	1,78 (1,96)	1,31 (1,49)	1,11 (1,23)	0,84 (0,96)	0,63 (0,73)	0,71 (0,81)	4,66 m
-2.0	2,02 (9,01)	2,35 (9,34)	1,89 (2,24)	1,48 (1,83)	1,66 (1,84)	1,29 (1,47)			0,64 (0,76)	0,72 (0,84)	3,87 m

Blade lowered, Standard Arm (1650 mm)

() the values in parenthesis are with additional ballast: 0.25 ton

A (m)	B (m)										MAX
	1.0		2.0		3.0		4.0		MAX		
4.0					*2,1 (*2,1)	1,42 (1,6)	*1,44 (*1,44)	0,94 (1,06)	*1,11 (*1,11)	0,73 (0,84)	4,19 m
3.0					*2,3 (*2,3)	1,41 (1,6)	*1,53 (*1,53)	0,93 (1,05)	*1,16 (*1,16)	0,7 (0,79)	4,83 m
2.0					*2,36 (*2,36)	1,41 (1,59)	*1,61 (*1,61)	0,93 (1,05)	*1,27 (*1,27)	0,67 (0,76)	5,16 m
1.0					*2,51 (*2,51)	1,38 (1,59)	*1,68 (*1,68)	0,9 (1,02)	*1,33 (*1,33)	0,65 (0,73)	5,23 m
0					*2,59 (*2,59)	1,35 (1,56)	*1,75 (*1,75)	0,87 (0,99)	*1,34 (*1,34)	0,66 (0,74)	5,08 m
-1.0	*2,8 (*2,8)	*2,78 (*2,78)	*2,78 (*2,78)	1,44 (1,79)	*2,54 (*2,54)	1,31 (1,53)	*1,74 (*1,74)	0,84 (0,96)	*1,32 (*1,32)	0,71 (0,81)	4,66 m
-2.0	*2,74 (*2,74)	*2,73 (*2,73)	*2,71 (*2,71)	1,48 (1,83)	*2,34 (*2,34)	1,29 (1,49)			*1,21 (*1,21)	0,72 (0,84)	3,87 m



Front



Side

Unit: ton

Blade raised, Optional Arm (1900 mm)

() the values in parenthesis are with additional ballast: 0.25 ton

A (m)	B (m)										
	1.0		2.0		3.0		4.0		MAX		
4.0					*1,8 (*1,98)	1,4 (1,58)	1,14 (1,26)	0,92 (1,04)	0,52 (0,63)	0,66 (0,77)	4,51 m
3.0					1,8 (1,98)	1,39 (1,57)	1,13 (1,25)	0,91 (1,03)	0,53 (0,63)	0,63 (0,72)	5,11 m
2.0					1,78 (1,96)	1,38 (1,56)	1,11 (1,24)	0,9 (1,03)	0,54 (0,63)	0,6 (0,69)	5,41 m
1.0					1,77 (1,95)	1,36 (1,54)	1,1 (1,22)	0,88 (1)	0,75 (0,83)	0,58 (0,66)	5,48 m
0					1,79 (1,97)	1,32 (1,5)	1,11 (1,24)	0,85 (0,97)	0,54 (0,63)	0,58 (0,67)	5,34 m
-1.0	1,96 (8,96)	2,37 (9,37)	1,81 (2,16)	1,41 (1,77)	1,76 (1,94)	1,29 (1,47)	1,08 (1,21)	0,81 (0,94)	0,56 (0,66)	0,64 (0,73)	4,95 m
-2.0	2 (8,99)	2,33 (9,32)	1,86 (2,22)	1,46 (1,81)	1,64 (1,82)	1,26 (1,44)			0,57 (0,69)	0,64 (0,77)	4,23 m

Blade lowered, Optional Arm (1900 mm)

() the values in parenthesis are with additional ballast: 0.25 ton

A (m)	B (m)										
	1.0		2.0		3.0		4.0		MAX		
4.0					*2,08 (*2,08)	1,4 (*1,58)	*1,42 (*1,42)	*0,92 (*1,04)	*1,04 (*1,04)	0,66 (0,77)	4,51 m
3.0					*2,28 (*2,28)	1,39 (*1,58)	*1,51 (*1,51)	*0,91 (*1,03)	*1,09 (*1,09)	0,63 (0,72)	5,11 m
2.0					*2,34 (*2,34)	1,38 (*1,57)	*1,59 (*1,59)	*0,9 (*1,03)	*1,19 (*1,19)	0,6 (0,69)	5,41 m
1.0					*2,49 (*2,49)	1,36 (1,56)	*1,66 (*1,66)	0,88 (1)	*1,26 (*1,26)	0,58 (0,66)	5,48 m
0					*2,57 (*2,57)	1,32 (1,54)	*1,73 (*1,73)	0,85 (0,97)	*1,27 (*1,27)	0,58 (0,67)	5,34 m
-1.0	*2,78 (*2,78)	*2,76 (*2,76)	*2,76 (*2,76)	1,41 (1,77)	*2,51 (*2,51)	1,29 (1,5)	*1,71 (*1,71)	0,81 (0,94)	*1,25 (*1,25)	0,64 (0,73)	4,95 m
-2.0	*2,72 (*2,72)	*2,71 (*2,71)	*2,69 (*2,69)	1,46 (1,81)	*2,32 (*2,32)	1,26 (1,47)			*1,14 (*1,14)	0,64 (0,77)	4,23 m

LIFTING CAPACITY

The lifting capacity is based on ISO 10567 and does not exceed 75% of the static tipping load or 87% of the hydraulic lifting capacity of the machine.

The straddle refers to the centre of rotation.

* Indicates the hydraulic load limit.

0 m refers to ground level.

The machine is understood to be equipped with a cab, rubber tracks, without a bucket and without a quick coupling.

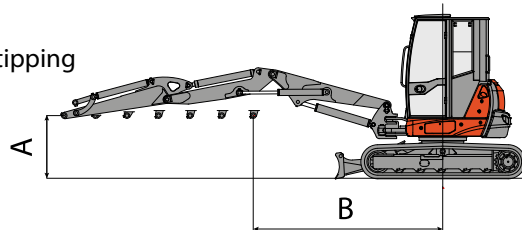

Front

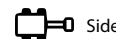

Side

Unit: ton

Blade raised, Standard Arm (1650 mm)

() the values in parenthesis are with additional ballast: 0.2 ton

A (m)	B (m)												MAX
			2.0		3.0		4.0		5.0		MAX		
	Front	Side	Front	Side	Front	Side	Front	Side	Front	Side	Front	Side	
5.0							1,16 (1,26)	0,9 (1)			0,73 (0,82)	0,67 (0,76)	4,26 m
4.0					1,68 (1,68)	1,41 (1,41)	1,15 (1,15)	0,93 (0,93)	0,9 (0,97)	0,59 (0,66)	0,67 (0,74)	0,61 (0,68)	5,14 m
3.0					1,65 (1,65)	1,4 (1,4)	1,14 (1,14)	0,93 (0,93)	0,93 (1,01)	0,6 (0,67)	0,61 (0,67)	0,55 (0,61)	5,65 m
2.0					1,61 (1,61)	1,38 (1,38)	1,13 (1,13)	0,92 (0,92)	0,92 (0,99)	0,63 (0,7)	0,57 (0,62)	0,48 (0,54)	5,93 m
1.0					1,57 (1,57)	1,37 (1,37)	1,12 (1,12)	0,9 (0,9)	0,91 (0,98)	0,63 (0,71)	0,54 (0,59)	0,49 (0,55)	5,99 m
0	*2,78 (*2,78)	*2,61 (*2,61)			1,59 (1,59)	1,32 (1,32)	1,13 (1,13)	0,87 (0,87)	0,93 (1)	0,69 (0,76)	0,6 (0,65)	0,54 (0,59)	5,86 m
-1.0	*2,73 (*2,73)	*2,59 (*2,59)	*2,61 (*2,61)	*1,65 (*1,65)	1,56 (1,56)	1,3 (1,3)	1,1 (1,1)	0,83 (0,83)	0,9 (0,97)	0,64 (0,71)	0,84 (0,9)	0,55 (0,61)	5,51 m
-2.0	*2,69 (*2,69)	*2,56 (*2,56)	*2,67 (*2,67)	*1,7 (*1,7)	1,5 (1,5)	1,31 (1,31)	1,08 (1,08)	0,75 (0,75)			0,75 (0,82)	0,6 (0,67)	4,90 m
-3.0			*2,61 (*2,61)	*1,67 (*1,67)	1,35 (1,49)	1,35 (1,49)					0,9 (1)	0,73 (0,83)	3,85 m

Blade lowered, Standard Arm (1650 mm)

() the values in parenthesis are with additional ballast: 0.2 ton

A (m)	B (m)												MAX
			2.0		3.0		4.0		5.0		MAX		
	Front	Side	Front	Side	Front	Side	Front	Side	Front	Side	Front	Side	
5.0							*1,39 (*1,39)	0,9 (1)			*0,69 (*0,69)	0,67 (0,76)	4,26 m
4.0					*2,08 (*2,08)	1,41 (0)	*1,43 (*1,43)	0,93 (0,93)	*1,08 (*1,08)	0,59 (0,66)	*0,7 (*0,7)	0,61 (0,68)	5,14 m
3.0					*2,28 (*2,28)	1,4 (1,41)	*1,53 (*1,53)	0,93 (0,93)	*1,09 (*1,09)	0,6 (0,67)	*0,78 (*0,78)	0,55 (0,61)	5,65 m
2.0					*2,34 (*2,34)	1,38 (1,4)	*1,6 (*1,6)	0,92 (0,92)	*1,2 (*1,2)	0,63 (0,7)	*0,86 (*0,86)	0,48 (0,54)	5,93 m
1.0					*2,49 (*2,49)	1,37 (1,38)	*1,67 (*1,67)	0,9 (0,9)	*1,26 (*1,26)	0,63 (0,71)	*0,92 (*0,92)	0,49 (0,55)	5,99 m
0					*2,57 (*2,57)	1,32 (1,37)	*1,74 (*1,74)	0,87 (0,87)	*1,35 (*1,35)	0,69 (0,76)	*0,99 (*0,99)	0,54 (0,59)	5,86 m
-1.0	*2,78 (*2,78)	*2,61 (*2,61)	*2,69 (*2,69)	*1,65 (*1,65)	*2,52 (*2,52)	1,3 (1,32)	*1,65 (*1,65)	0,83 (0,83)	*1,28 (*1,28)	0,64 (0,71)	*0,93 (*0,93)	0,55 (0,61)	5,51 m
-2.0	*2,73 (*2,73)	*2,59 (*2,59)	*2,67 (*2,67)	*1,7 (*1,7)	*2,33 (*2,33)	1,31 (1,3)	*1,62 (*1,62)	0,75 (0,75)			*0,86 (*0,86)	0,6 (0,67)	4,90 m
-3.0	*2,69 (*2,69)	*2,56 (*2,56)	*2,61 (*2,61)	*1,67 (*1,67)	*2,26 (*2,26)	1,35 (1,31)					*0,85 (*0,85)	0,73 (0,83)	3,85 m



Front















Side

Unit: ton













Blade raised, Optional Arm (1900 mm)

() the values in parenthesis are with additional ballast: 0.2 ton

A (m)	B (m)												
			2.0		3.0		4.0		5.0		MAX		
													
5.0							1,14 (1,23)	0,88 (0,98)			0,66 (0,75)	0,6 (0,69)	4,63 m
4.0					1,66 (1,66)	1,38 (1,38)	1,13 (1,13)	0,91 (0,91)	0,87 (0,95)	0,57 (0,64)	0,6 (0,67)	0,54 (0,61)	5,43 m
3.0					1,62 (1,62)	1,38 (1,38)	1,12 (1,12)	0,9 (0,9)	0,91 (0,99)	0,57 (0,65)	0,54 (0,6)	0,48 (0,54)	5,92 m
2.0					1,59 (1,59)	1,36 (1,36)	1,11 (1,11)	0,9 (0,9)	0,9 (0,97)	0,6 (0,68)	0,49 (0,55)	0,41 (0,47)	6,18 m
1.0					1,55 (1,55)	1,35 (1,35)	1,1 (1,1)	0,87 (0,87)	0,89 (0,96)	0,61 (0,69)	0,46 (0,52)	0,42 (0,48)	6,24 m
0					1,56 (1,56)	1,29 (1,29)	1,11 (1,11)	0,84 (0,84)	0,9 (0,98)	0,66 (0,74)	0,52 (0,58)	0,46 (0,52)	6,11 m
-1.0	*2,76 (*2,76)	*2,58 (*2,58)	*2,59 (*2,59)	*1,63 (*1,63)	1,53 (1,53)	1,28 (1,28)	1,08 (1,08)	0,81 (0,81)	0,87 (0,95)	0,62 (0,69)	0,76 (0,83)	0,48 (0,54)	5,79 m
-2.0	*2,71 (*2,71)	*2,57 (*2,57)	*2,65 (*2,65)	*1,68 (*1,68)	1,47 (1,47)	1,29 (1,29)	1,06 (1,06)	0,72 (0,72)			0,67 (0,75)	0,52 (0,6)	5,21 m
-3.0	*2,67 (*2,67)	*2,54 (*2,54)	*2,58 (*2,58)	*1,64 (*1,64)	1,32 (1,47)	1,32 (1,47)					0,82 (0,93)	0,66 (0,76)	4,26 m

Blade lowered, Optional Arm (1900 mm)

() the values in parenthesis are with additional ballast: 0.2 ton

A (m)	B (m)												
			2.0		3.0		4.0		5.0		MAX		
													
5.0							*1,37 (*1,37)	0,88 (0,98)			*0,62 (*0,62)	0,6 (0,69)	4,63 m
4.0					*2,06 (*2,06)	1,38 (-0,02)	*1,41 (*1,41)	0,91 (0,91)	*1,06 (*1,06)	0,57 (0,64)	*0,63 (*0,63)	0,54 (0,61)	5,43 m
3.0					*2,26 (*2,26)	1,38 (1,38)	*1,51 (*1,51)	0,9 (0,9)	*1,07 (*1,07)	0,57 (0,65)	*0,71 (*0,71)	0,48 (0,54)	5,92 m
2.0					*2,32 (*2,32)	1,36 (1,38)	*1,58 (*1,58)	0,9 (0,9)	*1,17 (*1,17)	0,6 (0,68)	*0,79 (*0,79)	0,41 (0,47)	6,18 m
1.0					*2,47 (*2,47)	1,35 (1,36)	*1,65 (*1,65)	0,87 (0,87)	*1,24 (*1,24)	0,61 (0,69)	*0,85 (*0,85)	0,42 (0,48)	6,24 m
0					*2,55 (*2,55)	1,29 (1,35)	*1,72 (*1,72)	0,84 (0,84)	*1,33 (*1,33)	0,66 (0,74)	*0,92 (*0,92)	0,46 (0,52)	6,11 m
-1.0	*2,76 (*2,76)	*2,58 (*2,58)	*2,67 (*2,67)	*1,63 (*1,63)	*2,5 (*2,5)	1,28 (1,29)	*1,63 (*1,63)	0,81 (0,81)	*1,26 (*1,26)	0,62 (0,69)	*0,86 (*0,86)	0,48 (0,54)	5,79 m
-2.0	*2,71 (*2,71)	*2,57 (*2,57)	*2,65 (*2,65)	*1,68 (*1,68)	*2,31 (*2,31)	1,29 (1,28)	*1,6 (*1,6)	0,72 (0,72)			*0,79 (*0,79)	0,52 (0,6)	5,21 m
-3.0	*2,67 (*2,67)	*2,54 (*2,54)	*2,58 (*2,58)	*1,64 (*1,64)	*2,24 (*2,24)	1,32 (1,29)					*0,78 (*0,78)	0,66 (0,76)	4,26 m



EUROCOMACH®

MADE IN ITALY

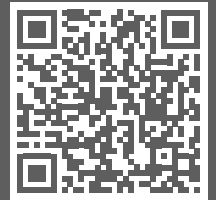

Sampierana S.p.a.

47021 S.Piero in Bagno (FC)

via Leonardo da Vinci, 40

Tel +39 0543.904211

Fax +39 0543.918520

www.sampierana.com



COMPANY WITH
QUALITY SYSTEM
CERTIFIED BY DNV GL
= ISO 9001 =

The information contained in this brochure is of a general nature. Sampierana S.p.A. reserves the right to change the product technical data and characteristics at any time without prior notice. The photographs are for illustrative purposes only and do not necessarily refer to products in standard conditions. For instructions on the correct use of the products, please consult the use and maintenance manual. Sampierana S.p.A. shall not be liable for damages or injuries resulting from failure to follow the instructions contained in the use and maintenance manual.